

## Specification of NDB5 series CBE

**Product Name: Circuit breaker for equipment**

**Models: NDB5**

**Date: 20181030**

<b>Made</b>	<b>Checked</b>	<b>Approved</b>
<b>Kang Fan</b>	<b>Zhang Jian</b>	<b>Duan Hui</b>

<b>Revision</b>			
<b>Edition</b>	<b>Revised contents and reasons</b>	<b>Date</b>	<b>Revision</b>
0	First edition publication	20130730	Kang Fan
1	<ol style="list-style-type: none"> <li>1. Add type indication for accessory to 2<sup>nd</sup> item;</li> <li>2. Add electrical parameter for accessory to 3<sup>rd</sup> item;</li> <li>3. Add Configuration &amp; Installation Dimension image for accessory and circuit breaker to 6<sup>th</sup> item;</li> <li>4. Add indication and wiring diagram for accessory.</li> </ol>	20150422	Kang Fan
2	Delete infrequently used auxiliary functions	20160614	Zhang Jian
3	<ol style="list-style-type: none"> <li>1.Change the Logo "Nader"</li> <li>2.Change the technical parameters</li> </ol>	20170620	Zhang Jian
4	Unified updated version according to the requirements of company	20181030	Kang Fan

	File name	Product specification	File number	NDT500473
	Product Name	Circuit breaker for equipment	Edition	4 version
			Implementation date	20181030

## 1 Application

NDB5 series circuit breaker for equipment (hydraulic-magnetic circuit breaker) is applied in electrical system, of which the rated current is from 0.5A to 63A and the rated voltage is AC230/400V, AC250V, AC480/277V (50/60Hz) or up to DC125V, to protect the circuit against the overload current and short-circuit current. It is also can be used to make and break the circuit infrequently. The product is widely used in computer and its peripheral equipment, industrial automation devices, telecommunication equipments, power supply for telecommunication, UPS equipments, railway-engine, marine electrical systems, aerospace electrical power system, elevator control systems and mobile power equipments.

## 2 Product Photos

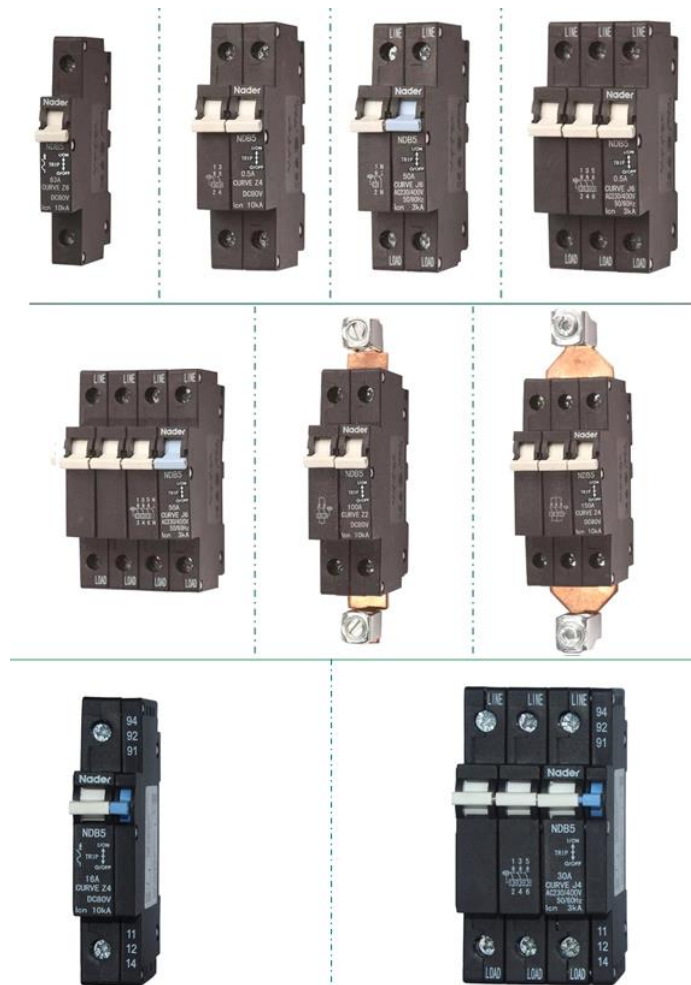

File number	NDT500473	Edition	4 version	Implementation date	20181030
-------------	-----------	---------	-----------	---------------------	----------

### 3 Model and Implication

ND B 5 Z4 80/2 P U 0-W - R XXXXX

1 2 3 4 5 6 7 8 9 10 11 12

Sr. No.	Illustration /Code	NDB5
1	Enterprise code	ND "Nader" brand
2	Product code	B Circuit Breaker for Equipment
3	Design code	5
4	Tripping curve	Z2 DC short delay Z4 DC medium delay Z6 DC long delay J2 AC 50/60Hz Short delay J4 AC 50/60Hz Medium delay J6 AC 50/60Hz Long delay
5	Rated current (A)	0.5, 0.6, 0.7, 0.8, 0.9, 1, 1.5, 2, 2.5, 3, 3.5, 4, 4.5, 5, 5.5, 6, 6.5, 7, 7.5, 8, 8.5, 9, 9.5, 10, 12, 15, 16, 20, 24, 25, 30, 32, 35, 40, 45, 50, 55, 60, 63, 70, 80, 90, 100, 105, 110, 120, 125, 150
6	Number of Poles	1 One-pole 2 Two-pole 3 Three-pole
7	Neutral-Pole	P N/A N With neutral-pole (1N or 3N)
8	Connection type	U With parallel connection busbar, for 2 poles in parallel or 3 poles in parallel Empty for not parallel
9	Accessories	0 Without accessory 1 Auxiliary contact; 2 single auxiliary contact
10	Outline type	Empty for 45mm W 57mm
11	Certification	R - CCC、UL 1077、TUV、CE L - CCC、UL 489A、TUV、CE
12	Customer Code	Upon customers' requests

**Note:**

- (1) The maximum rated current for 1-pole is 63A.
- (2) 1P + N, 3P and 3P+N breakers are only available for AC type breaker.
- (3) Parallel connected products only available for DC breakers. Furthermore, 2 pole parallel is minimum for 20A, the maximum for 100A; 3 pole parallel is minimum for 105A, and maximum for 150A
- (4) NDB5 series HMCB can attach with auxiliary and alarm contact;

File number	NDT500473	Edition	4 version	Implementation date	20181030
-------------	-----------	---------	-----------	---------------------	----------

There are two types of accessories available, auxiliary alarm contact and single auxiliary contact.

1: Auxiliary alarm contact is consisted by a set of auxiliary contact (1NO+1NC) and a set of alarm contact (1NO+1NC) .

2: Single auxiliary contact is consisted by a set of auxiliary contact (1NO+1NC);

Accessory is assembled on the right pole of circuit breaker

Auxiliary contact is used to indicate the breaking-closing status of circuit breaker;

Alarm contact indicates circuit breaker`s fault tripping status;

Auxiliary and alarm contact should be bought with circuit breaker.

NDB5 series circuit breaker for equipment with accessories products comply with CCC certification requirements.

(5) Above table lists are common types. The tripping curve, rated current, etc. can be made according to the client's requirements. Special type will be made for those products which are made according to client's requirement and won't be listed in the above table.

#### 4 Main Specifications

Number of Poles	1P		1N	2P		3P	3N	2PU	3PU	
Rated Voltage	AC230/ 240/250 V	DC80/12 5V	AC230/ 240/250 V	AC400/415V AC480/277V	DC80/ 125V	AC400/415V AC480/277V		DC80V		
Rated Current (A)	0.5,0.6,0.7,0.8,0.9,1,1.5,2,2.5,3,3.5,4,4.5,5,5.5,6,6.5,7,7.5,8,8.5,9,9.5,10,12,15,16,20,24,25,30,32,35,40,45,50,55,60,63		0.5, 0.6, 0.7, 0.8, 0.9, 1, 1.5, 2, 2.5,3, 3.5, 4, 4.5, 5, 5.5, 6, 6.5, 7, 7.5, 8, 8.5, 9, 9.5, 10, 12, 15, 16, 20, 24, 25, 30, 32, 35, 40, 45, 50						20,3 0,40, 50,6 0,63, 70,8 0,90, 100	105, 110, 120, 125, 135, 150
Installation	35mm DIN Rail & Miniature Rail									
Tripping Curve	J2,J4,J6	Z2,Z4,Z6	J2,J4,J6	J2,J4,J6	Z2,Z4,Z6	J2,J4,J6		Z2,Z4,Z6		

- Comply with standards: IEC/EN 60934, IEC/EN 60947-2, GB/T 17701, GB/T 14048.2, UL1077, UL489A
- Rated working voltage: DC80V, DC125V, AC230/240/250V, AC400/415V, AC480/277V
- Frequency: 50/60Hz
- Mechanical endurance: 10000 times (including electrical endurance: 6000 times)
- Auxiliary/alarm contact technical parameters:  
Auxiliary contact: DC125V 0.5A, AC 250V 6A; Alarm contact: DC250V 0.25A, AC250V 5A;  
Mechanical & electrical life: 15000 times (electrical life 10000 times);  
Working frequency withstand voltage: 1500V;
- Certificates: CCC, UL1077, UL489A, TUV, CE
- Cable Capacity: 0.5~25mm<sup>2</sup>, up to 35 mm<sup>2</sup>(2P in parallel:), up to 70 mm<sup>2</sup>(3P in parallel)

File number	NDT500473	Edition	4 version	Implementation date	20181030
-------------	-----------	---------	-----------	---------------------	----------

➤ **Rated interrupting capacity:**

Rated current (A)	Rated voltage (V)	Interrupting Capacity (kA)				
		CCC	UL		TUV/CE	
		GB/T 17701	UL 1077	UL 489A	EN6093	EN60947-2
0.5~63	DC80	10	10, U1	10	10	10
	DC125	6	/	/	6	/
	AC230/400	6	/	/	6	/
	AC480/277	/	6, U1	/	/	/
	AC250	/	6, U1	/	/	/
20~150 (Multi pole in parallel)	DC80	/	10, U1	10	/	/

**5 Normal condition for operation**

- Altitude: ≤2000m
- Ambient temperature: -40℃~+85℃
- Relative humidity: The relative humidity of the air does not exceed 50% at the maximum temperature of +40℃. Higher relative humidities may be permitted at lower temperature, e.g. 90% at +20℃.
- Pollution degree: 2
- Installation type: II
- Service place should be without explosive media, gas and dust which are corrosive and conductive.
- The product should be mounted free from rain and snow.

**6 Tripping characteristic**

**6.1 Tripping times in second (tested under cold status)**

Current Curve	1.05In	1.3 In	2 In	6 In	10 In
Z2/J2	No trip	9-240	2-12	0.004-0.03	0.0035-0.018
Z4	No trip	15-240	4-20	0.01-1	0.0035-0.1
J4	No trip	20-360	6-40	0.01-1.8	0.0035-0.1
Z6/J6	No trip	60-1200	20-100	1.2-7	0.0055-2.2

**6.2 Tripping curve**

File number	NDT500473	Edition	4 version	Implementation date	20181030
-------------	-----------	---------	-----------	---------------------	----------

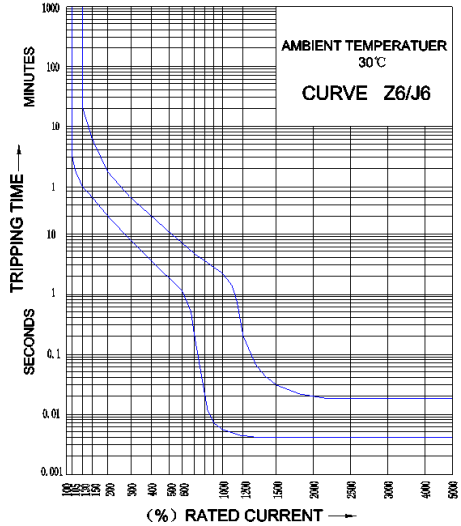
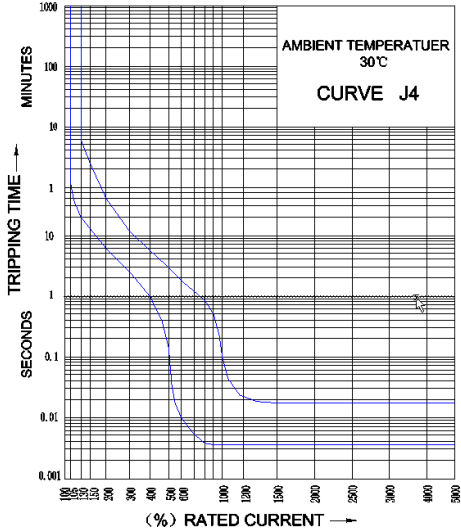
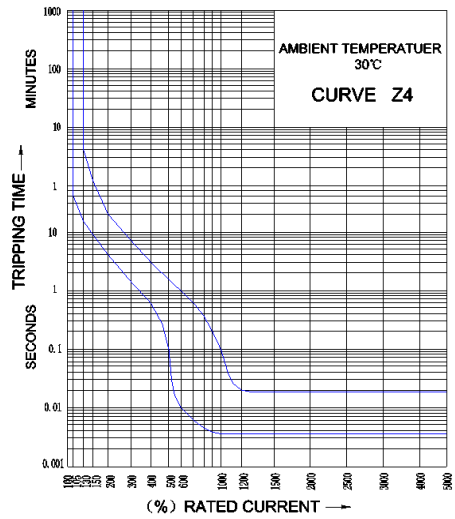
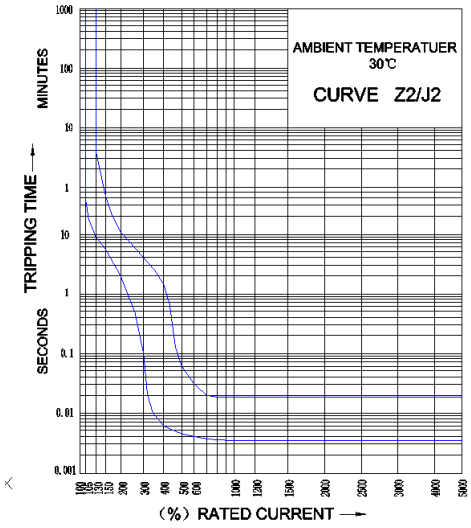

## 7 Product Configuration & Installation Dimension

### 1) Configuration & Installation Dimension of the product with 45mm operation face

File number	NDT500473	Edition	4 version	Implementation date	20181030
-------------	-----------	---------	-----------	---------------------	----------

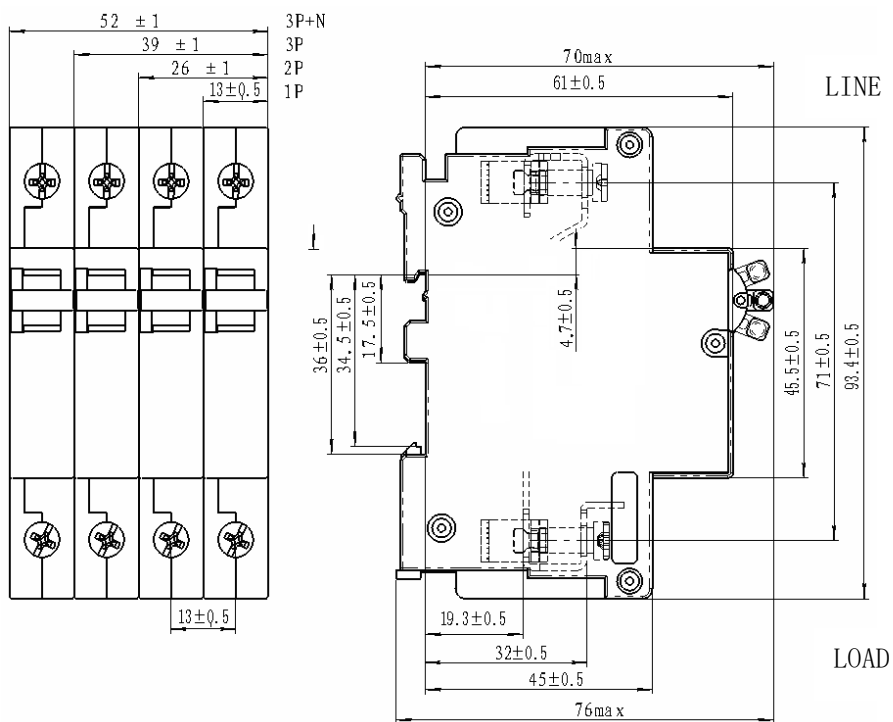

**2) Configuration & Installation Dimension of the product with 57mm operation face**

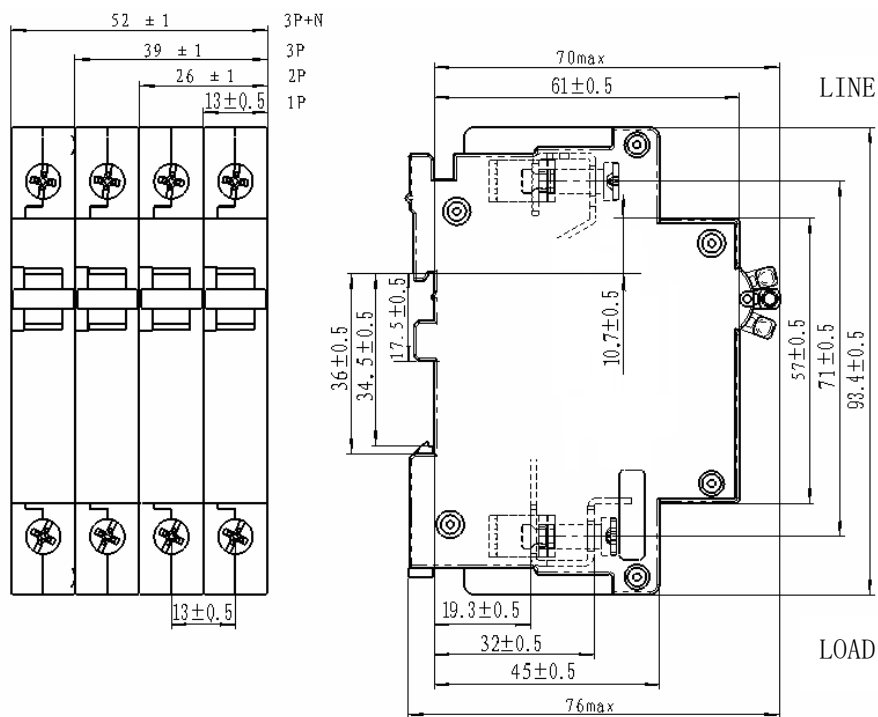



File number	NDT500473	Edition	4 version	Implementation date	20181030
-------------	-----------	---------	-----------	---------------------	----------

### 3) Configuration and Dimension of parallel connection product

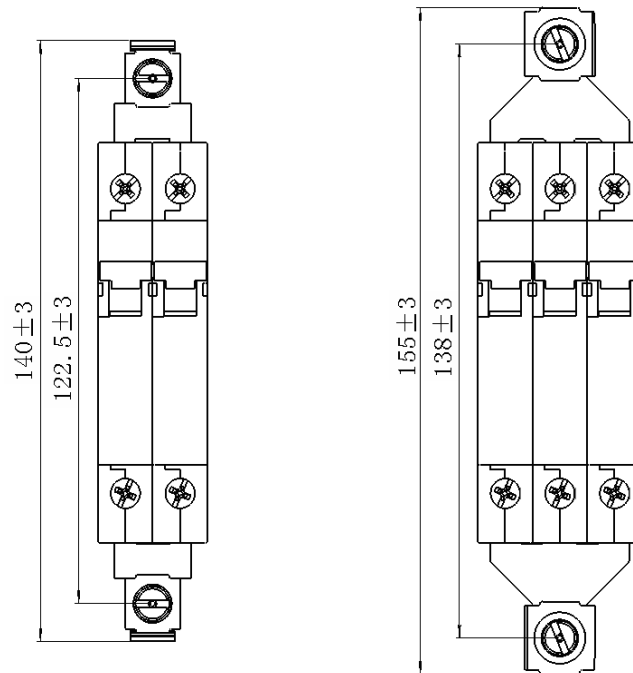

### 4) Configuration & Installation Dimension of the product with Auxiliary/alarm contact: a:

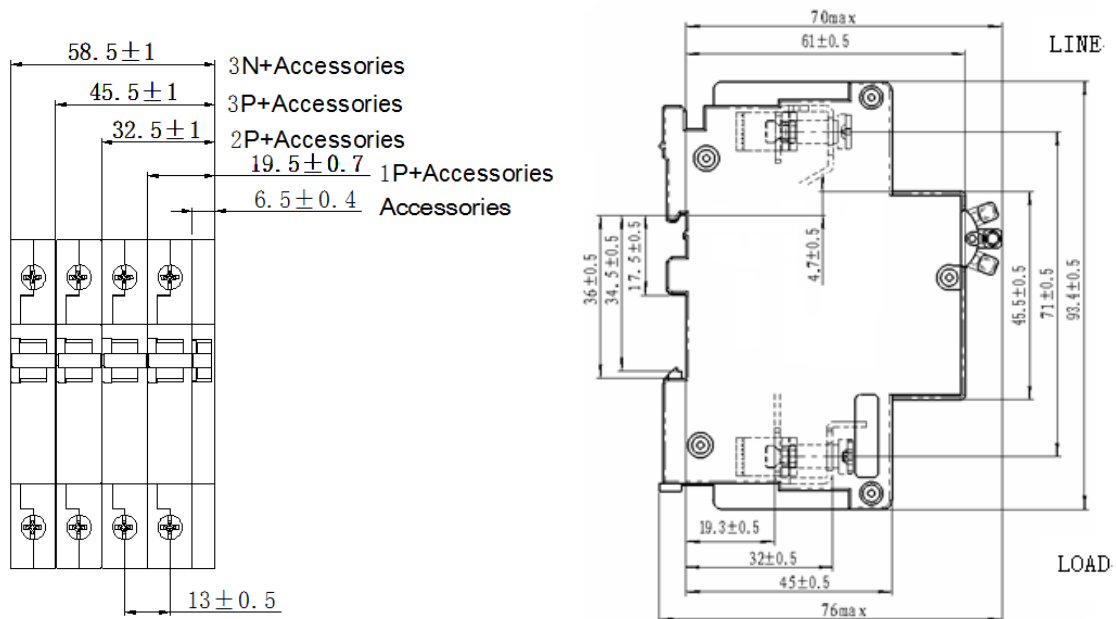

File number	NDT500473	Edition	4 version	Implementation date	20181030
-------------	-----------	---------	-----------	---------------------	----------

b:

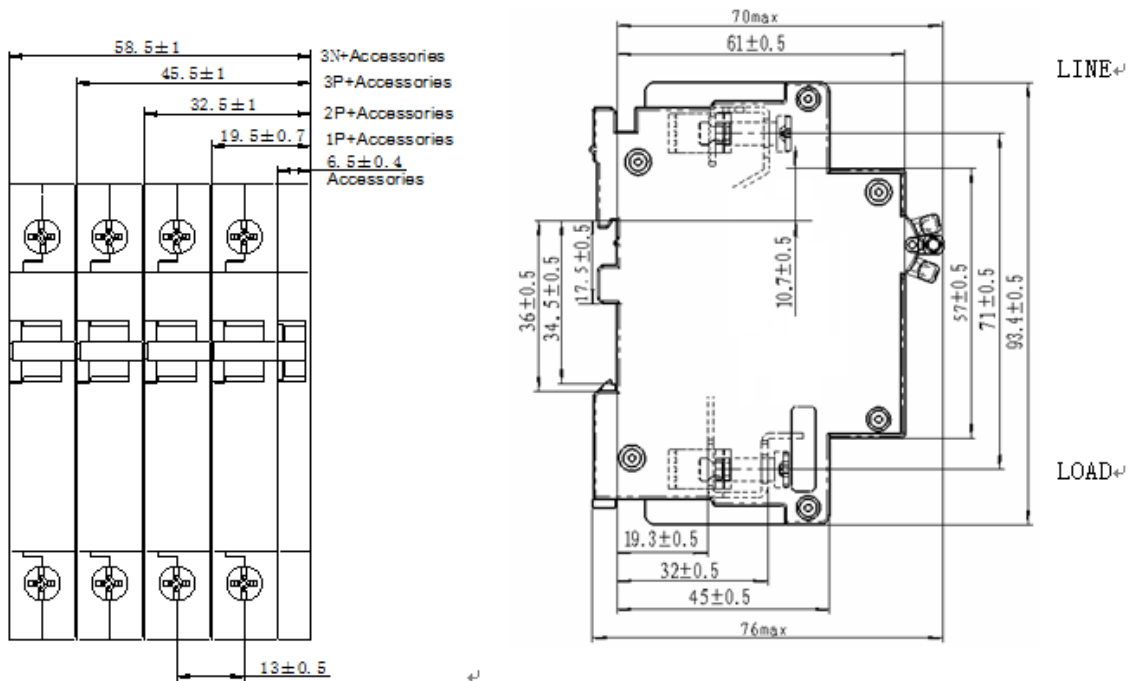

## 8 Installation and operation requirements

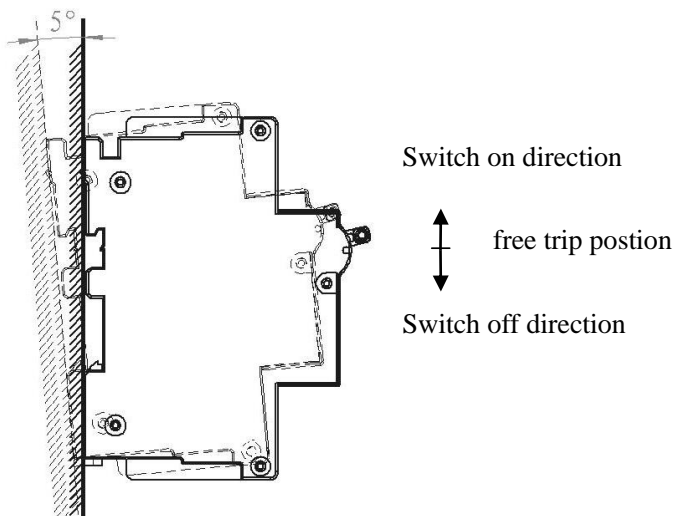

**DIN Rail Installation.** The breaker should be mounted within 5° of the mounting plane in case the characters of the product are affected.

**Operation method :** The product handle can stay in three position, which will indicate three working status of the product accordingly. When the handle stay in free trip position, the product handle should be turned off to the end of the switch off direction and kept at the position for at least one second firstly so that the mechanism can be related. Then the product can be switched on to fulfill the function of loading and protecting. When the handle is at the switch off position, the product can be switched on by turning the handle to fulfill the function of loading and protecting. When the handle is at the switch on position, the product can be switched off either by turning the handle to cut off the load or automatic tripping to

File number	NDT500473	Edition	4 version	Implementation date	20181030
-------------	-----------	---------	-----------	---------------------	----------

free trip position in specific time when the loading increase to conventional tripping current.

**9、 The wiring diagram of accessory**

**1) The wiring diagram of auxiliary contact**

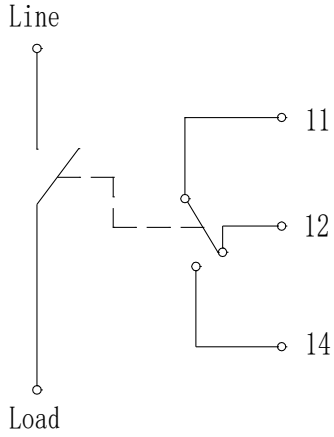

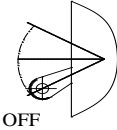
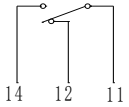
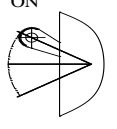
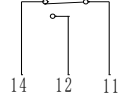
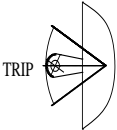
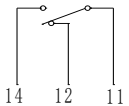
The status diagram for handle`s position		
CB status	Handle position	Auxiliary contact status
OFF		
ON		
Electrical tripping		

**2) The wiring diagram for alarm contact**

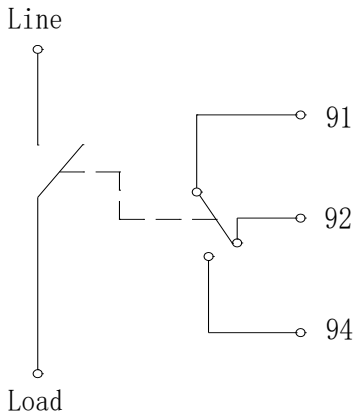

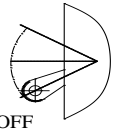
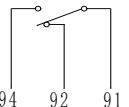
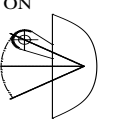
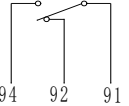
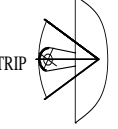
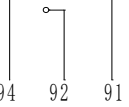
The status diagram for handle`s position		
CB status	Handle position	Alarm contact status
OFF		
ON		
Electrical tripping		

File number	NDT500473	Edition	4 version	Implementation date	20181030
-------------	-----------	---------	-----------	---------------------	----------

## 10、 Accessory list and installation

10.1 NDB5 series HMCB can attach a pair of auxiliary contact and a pair of alarm contact at the same time. The terminal of auxiliary and alarm contact is pluggable connection strap.

Please refer below picture. “11,12,14”are auxiliary contact number,“91,92,94” are alarm contact number.

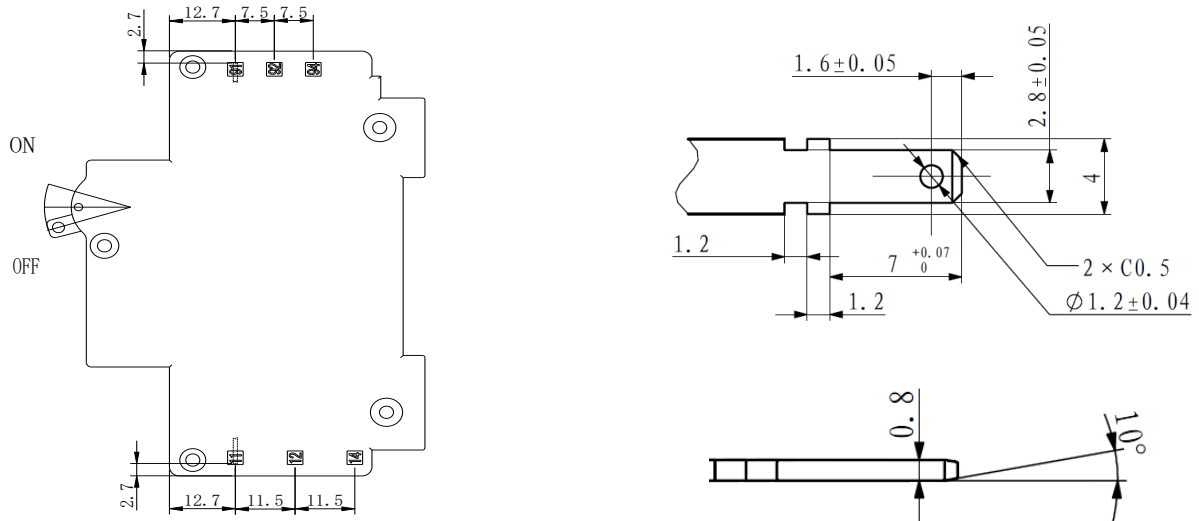

10.2 NDB5 series HMCB can attach only one pair of auxiliary signal function, which terminal is pluggable connection strap.

Please refer below picture for auxiliary contact, “11,12,14” are auxiliary contact terminal number.

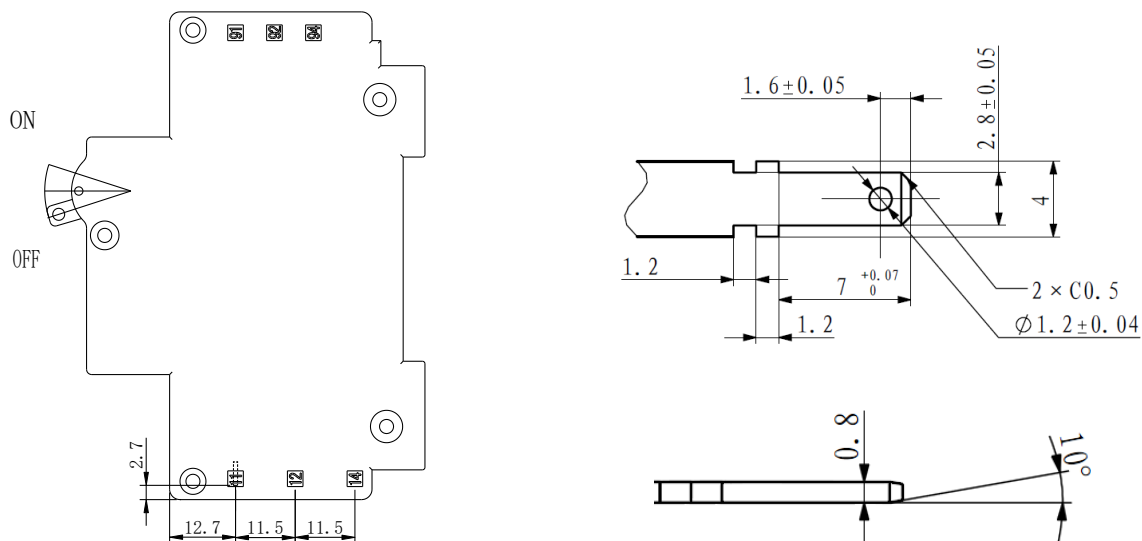

## 11 Packing and Storing

Max packing capacity (1P product: 12 pcs/box, 2P、1N product: 6 pcs/box, 2PU product: 3 pcs/box, 3P product: 4 pcs/box, 3PU product: 2 pcs/box, 3N product: 3 pcs/box; 1P product with accessory: 8 pcs/box, 2P、1N product: 4 pcs/box, 2PU product: 2 pcs/box, 3P product: 3 pcs/box, 3PU product: 2 pcs/box, 3N product: 2 pcs/box);

The product should be transited and deposited free from rain and snow. The products

File number	NDT500473	Edition	4 version	Implementation date	20181030
-------------	-----------	---------	-----------	---------------------	----------

should be stored in the warehouse where there are ventilation. The relative humidity there should not exceed 90% ( $20\pm 5^{\circ}\text{C}$ ), and the ambient temperature there is between  $-40^{\circ}\text{C}$  to  $+85^{\circ}\text{C}$ . In addition, there should not be acidic, alkaline and corrosive gas in the air. The products should not be deposited more than 3 years in the above mentioned conditions since the producing date.

#### 12 Safety notice

- 1) Do not disassemble the product with permission.
- 2) Attention to live part when the breaker is energized and avoid touching them.
- 3) Please make sure reliable connection to avoid fault tripping or terminal damage caused by exceptional heat resulting from unsuitable connection. During installation, the fasten torque of the body screw should be 2N.m, it should be 3.5 N.m fasten torque for the busbar screw of the two pole parallel product and 10 N.m for the three pole parallel product.
- 4) Please maintain the distance of 30mm from the arc jet slot of the product during installation to avoid short current.